

Model HC3 600AJ

ARTICULATING BOOM LIFTS



MORE ECONOMIC

- Lift more with new capacity -300 kg unrestricted up to 454 kg restricted.

MORE PRODUCTIVE

- 3 working zones- be more flexible working safely at height with one machine.

MORE ACCESS

- 3 people allowed into the basket at the same time.
- Load sensing system calibration - no weights needed.
- Chassis tilt indicator of 5° with light alarm.
- Automatic selection of the capacity zone based on the load in the basket.

SMART DESIGN

- New light panel - improved visibility.



Standard Features

- Multiple function operation
- Full proportional drive joystick control with integral thumb steer switch
- Full proportional main boom and swing joystick control
- Multiple speed control for lower boom, telescope and platform rotate
- Selectable creep speed on drive / lift and swing functions
- Platform console machine status light panel *
- Load sensing system
- AC power cable to platform
- 13 mm air line to platform
- Engine distress warning /shut down system **
- Gull-wing turntable hoods
- Spark arresting type muffler
- Control ADE® (Advanced Design Electronics) System
- Hydrostatic drive transmission
- Four wheel drive
- Two wheel steer
- Horn
- 5 degree tilt alarm and indicator light
- Oscillating front axle
- Hour meter
- Ground control selector switch with key lock
- Skyguard Skyline active system
- Platform tool tray
- Swing-out engine tray

Standard Specifications

- Diesel Engine Deutz TD2.2 L3 (49hp, 36kw)
- Fuel Tank Capacity 113.6 L
- Hydraulic System 115.8 L
- Auxiliary Power 12V DC
- Tyres IN355/D625 (Foam Filled)

Accessories & Options

- 0.76 m x 1.20 m drop bar or swing gate
- 0.76 m x 1.53 m drop bar or swing gate
- 0.91 m x 1.83 m drop bar or swing gate
- 0.91 m x 2.44 m drop bar or swing gate
- 0.76 m x 0.91 m drop bar
- Tri entry 0.91 m x 1.83 m drop bar or swing gate
- Tri entry 0.91 m x 2.44 m drop bar or swing gate
- N355/55D625 Foam Filled Non Marking tyres
- SkyPower® package 4000 watt on-board generator
- SkyWelder® package 250 amp welder in the platform
- Tow package
- All motion alarm
- Light package ***
- Platform worklights
- Head and tail lights
- Flashing amber beacon
- Plugs & Sockets
- Hostile environment package ****
- Hydraulic oil cooler
- Catalytic purifier muffler
- Skyguard with beacon
- Skyguard without beacon
- Skyguard Skyeye active system
- Corner storage tray
- ClearSky Locate
- ClearSky CAN

* Provides indicator lights at platform control console for system distress, low fuel, tilt light, and foot switch status.

** Low oil pressure and high coolant temperature alarms with shut-down enabled/disabled by analyser.

*** Includes platform mounted work lights and head & tail lights.

**** Includes console cover, boom wipers and cylinder bellows.

Model HC3 600AJ

ARTICULATING BOOM LIFTS

Performance

• Working Height	20.51 m
• Platform Height	18.51 m
• Horizontal Outreach	12.37 m
• Working Outreach **	12.95 m
• Up and Over Height	8.09 m
• Swing	360° (Continuous)
• Platform Capacity (Restricted)	👤👤👤 340 kg/ 454 kg
• Platform Capacity (Unrestricted)	👤👤👤 300 kg
• Platform Rotator (Hydraulic)	180°
• Jib - Overall Length	1.83 m
• Jib - Range of articulation	130° (+70° / -60°)
A. Platform Size	0.91 m x 2.44 m
B. Overall Width (Axles Retracted)	2.49 m
C. Tailswing (working condition)	Zero
D. Stowed Height	2.58 m
E. Stowed Length	9.15 m
F. Wheelbase	2.48 m
G. Ground Clearance	0.30 m
• Machine weight *	11,292 kg
• Maximum Ground Bearing Pressure	5.3 kg/cm ²
• Maximum Tyre Load	5,806 kg
• Drive Speed 4WD	6.8 km/h
• Gradeability 4WD	45%
• Axle Oscillation	0.20 m
• Turning Radius - Inside	2.15 m
• Turning Radius - Outside	5.17 m



* Certain options or country standards may increase weight and/or dimensions
 ** Incl. 0.65 m outreach beyond platform

Reach Diagram

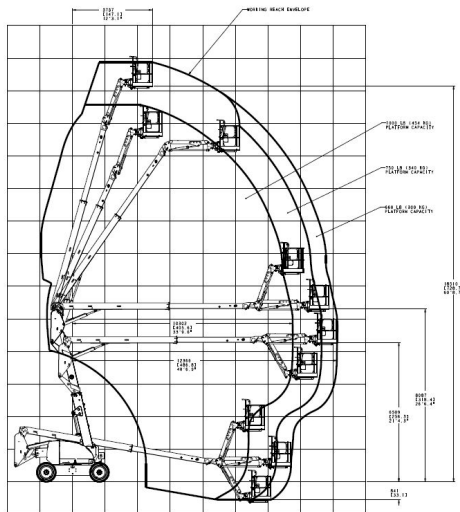

Dimensions

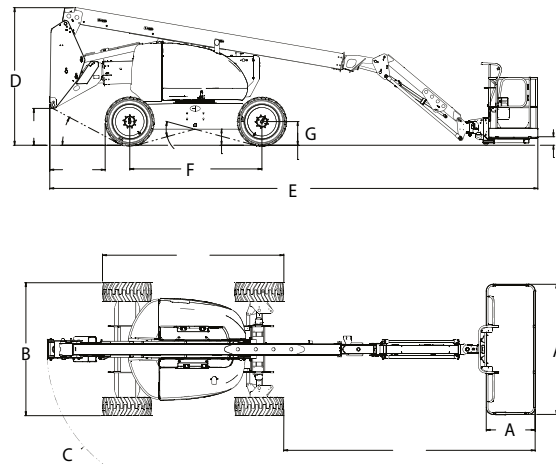

IMPORTANT

JLG is continually researching and developing products and reserves the right to make modifications without prior notice. All data in this document is indicative. Certain options or country standards will increase weight. Specifications may change to meet country standards or with the addition of optional equipment.

Due to continuous product improvements, JLG Industries reserves the right to make specification and/or equipment changes without prior notification.



JLG EMEA BV

Polaris Avenue 63
 2132 JH Hoofddorp
 The Netherlands
 Phone: +31 (0)23 565 5665
www.jlg.com

An Oshkosh Corporation Company