

Model 520AJ

ARTICULATING BOOM LIFT



MORE ECONOMIC

- Cut fuel consumption and operating costs with variable engine control.

MORE PRODUCTIVE

- Start work quicker with industry leading elevation time.*
Carry more tools and materials and be able to work longer with 250 kg basket weight capacity.

MORE ACCESS

- Increase your work envelope with more horizontal reach.**

SMART DESIGN

- Reduce maintenance with DuraTough turntable hood. High impact resistance and protects components.

*50% faster compared with previous model. Actual timings may vary.

** Compared with previous model.

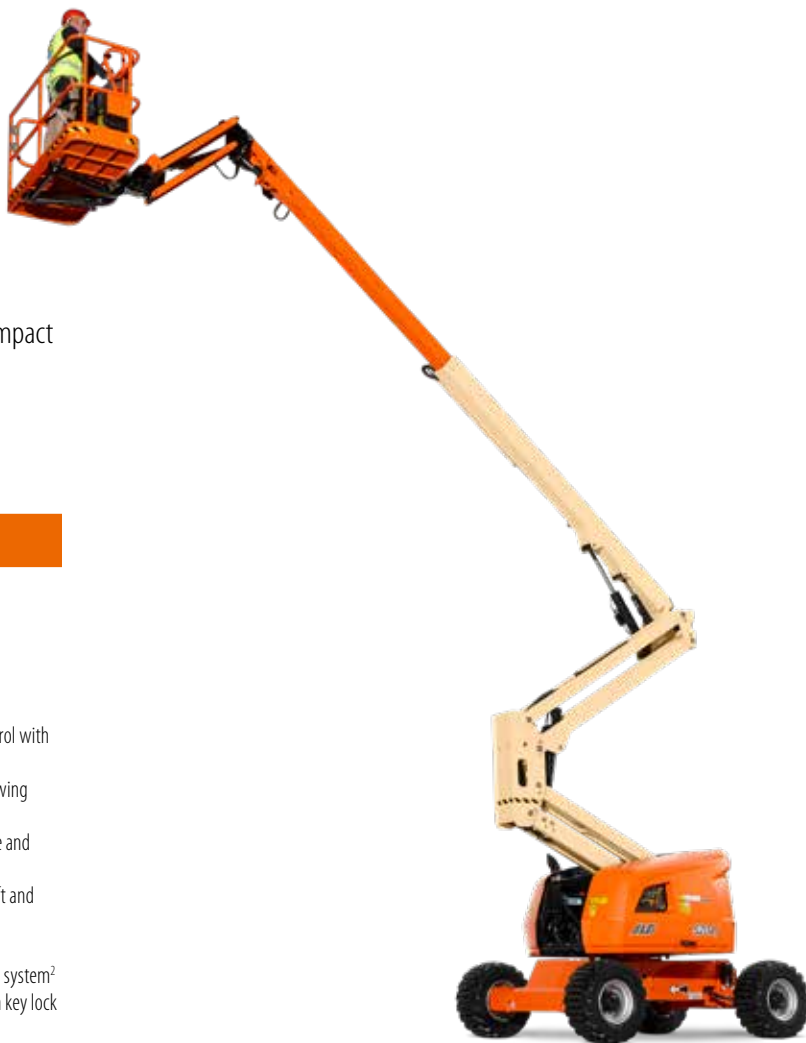

Standard Features

- 1.24 m Articulating Jib
- 0.76 m x 1.83 m Platform Side Entry
- 180 Degree Powered Platform Rotator
- Platform Console Machine Status Light Panel¹
- AC power cable to Platform
- 5 Degree Tilt Alarm/Indicator Light
- Swing Out Engine Tray
- Dura Tough gull-wing turntable hoods
- 12V-DC Auxiliary Power
- Hourmeter
- Interactive Display at Ground Controls
- Control ADE® Advanced Design Electronics System
- Lifting/Tie Down Lugs
- Horn
- Hydrostatic drive transmission
- Oscillating Front Axle
- Cast Aluminum Control Box
- Motion Alarm
- Platform Tool Tray
- Side entry with drop bar mid rail
- Multiple function operation
- Full proportional drive joystick control with integral thumb steer switch
- Full proportional main boom and swing joystick control
- Multiple speed control for telescope and platform rotate
- Selectable creep speed on drive / lift and swing functions
- Load sensing system
- Engine distress warning/shut down system²
- Ground control selector switch with key lock
- JLG Skyguard active system
- Low fuel engine cut-out

Standard Specifications

- Diesel Engine 36 kW (49hp) Deutz D2.9L4
- Fuel Tank Capacity 60.5 L
- Hydraulic System 144 L
- Auxiliary Power 12V DC
- Tyres 33/1550 x 16.5 (Foam Filled)

Accessories & Options

- 0.76 m x 1.22 m slide bar side entry platform
- 0.76 m x 1.22 m Self closing inward swing gate
- 0.76 m x 1.52 m slide bar side entry platform
- 13 mm airline to platform
- Flashing Amber Beacon
- Hostile Environment Kit³
- Light Package
- Platform Worklights
- Skypower 7,500W generator package
- PipeRack
- Catalytic exhaust purifier
- On-board 4,000W generator
- Spark arresting muffler
- Skyguard beacon (ILOS)
- Tow package
- Cold weather package
- Generator hourmeter
- Hydraulic Oil Cooler
- Synthetic Biodegradable Hydraulic Oil
- All motion alarm
- Head & Tail Lights
- Euro Plug & Socket
- Special paint colour
- Foam filled 315/55 D20 Tyres
- Non Mark FF 315/55 D20 Tyres
- 33 x 12-20 Solid Non-Marking Tyres
- Container transport wheels 33/1150 x 16.5

1 Provides indicator lights at platform control console for system distress, low fuel, tilt light, and foot switch status.

2 Low oil pressure and high coolant temperature alarms with shut-down enabled/disabled by analyser.

3 Includes console cover, boom wipers and cylinder bellows.

4 Includes platform mounted work lights and head & tail lights.

Model 520AJ

ARTICULATING BOOM LIFT

Performance

• Working Height	18.0 m
• Platform Height	16.0 m
• Horizontal Outreach	10.0 m
• Working Outreach **	10.65 m
• Up and Over Height	7.30 m
• Swing	355° (Non-Continuous)
• Platform Capacity (Unrestricted)	250 kg
• Platform Rotator (Hydraulic)	180°
• Jib - Overall Length	1.24 m
• Jib - Range of articulation	145° (+76°/-69°)
A. Platform Size	0.76 m x 1.83 m
B. Overall Width (Axles Retracted)	2.35 m
C. Tailswing (working condition)	Zero
D. Stowed Height	2.27 m
E. Stowed Length	7.77 m
F. Wheelbase	2.36 m
G. Ground Clearance	0.42 m
• Machine weight *	7,985 kg
• Maximum Ground Bearing Pressure	6.6 kg/cm ²
• Drive Speed 4WD	6.8 km/h
• Gradeability 4WD	45%
• Axle Oscillation	0.10 m
• Turning Radius - Inside	2.06 m
• Turning Radius - Outside	4.78 m



* Certain options or country standards may increase weight and/or dimensions
** Incl. 0.65 m outreach beyond platform

Reach Diagram

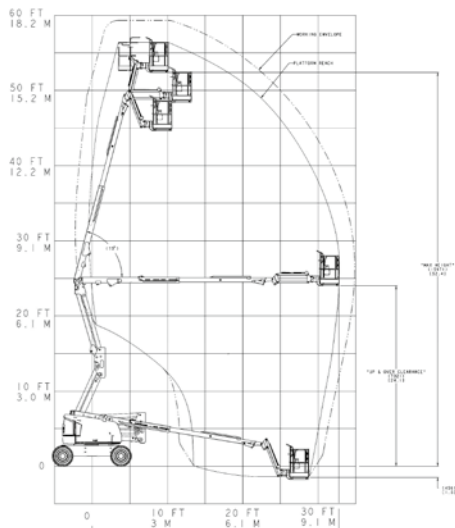

Dimensions

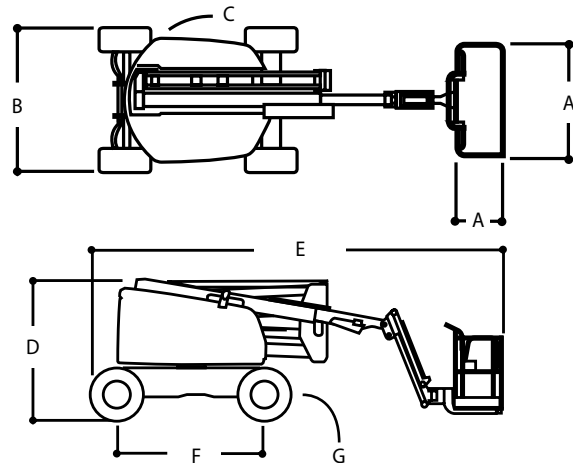

IMPORTANT

JLG is continually researching and developing products and reserves the right to make modifications without prior notice. All data in this document is indicative. Certain options or country standards will increase weight. Specifications may change to meet country standards or with the addition of optional equipment.

Due to continuous product improvements, JLG Industries reserves the right to make specification and/or equipment changes without prior notification.



JLG EMEA BV

Polaris Avenue 63
2132 JH Hoofddorp
The Netherlands
Phone: +31 (0)23 565 5665
www.jlg.com

An Oshkosh Corporation Company